

		L1 mm	L2 mm	L3 mm	B mm	H mm	boring hole Ø mm	art.-no.
1	cleat stainless steel		50	10			3,3	33801 050 55
			60	10			3,3	
			80	10			5,2	
			100	16			5,2	
2	cleat brass polished		40	9			3,2	33800 040 33
3	cleat plastic black		80	22			3,9	39051 308 00
			110	28			5,1	
			145	35			6,1	
			180	45			7,2	
			210	52			8,5	
4	cleat 2-hole aluminum silver anodised		80	22		10	9	33841 080 54
			100	25		15	10	
			125	31		19	12	
			150	37		22	16	
			200	52		32	23	
250	60		37	30				
5	cleat 4-hole aluminum silver anodised		80	27	26	10	12,5	33846 080 54
			100	31	34	14	13	
			125	41	39	19	14	
			150	43	45	22	18	
			200	63	52	32	25	
			250	70	58	36	30	
320	88	80	47	38				

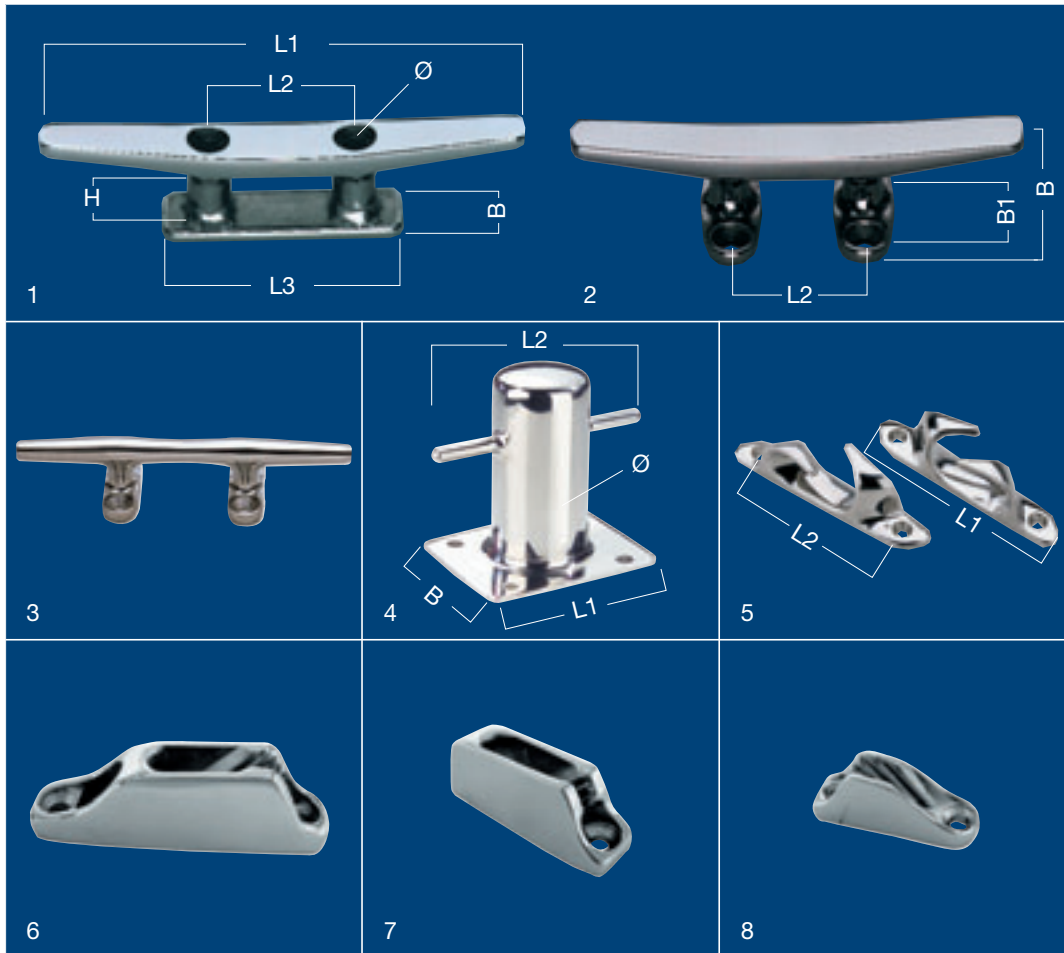

		L1 mm	L2 mm	L3 mm	H mm	B mm	B1 mm	for rope mm	boring hole Ø mm	Ø	art.-no.
1	cleat	100	30	50	15	16			4		33848 100 56
	2-hole	125	35	65	16	18			5		125 56
	AISI 316	150	45	73	19	22			5		150 56
	stainless steel	200	56	90	23	25			6,5		200 56
		250	71	110	24	28			8		250 56
2	cleat	100	30		14	35	25		5		33849 100 56
	4-hole	125	40		16	46	30		5		125 56
	AISI 316	150	51		18	60	42		6		150 56
	stainless steel	200	56		26	60	42		6		200 56
		250	54		30	65	46		6,5		250 56
3	cleat	150	58		20	44	26		6		33824 150 56
	4-hole	200	72		24	52	34		6,5		200 56
	AISI 316	250	91		30	67	44		8,0		250 56
	stainless steel	300	100		33	71	49		8,5		300 56
4	bitt	90	130			80			6	50	33830 050 56
	stainless steel	120	160			95			6	60	060 56
5	deck fairleads	115	96					12			34350 115 56 (pair)
6	cleat	55				15		3 - 6			36660 001 56
	AISI 316	70				17		3 - 6			002 56
	stainless steel	82				18		3 - 6			003 56
7	cleat	54				17		3 - 6			36661 000 56
8	cleat	48				14		3 - 6			36662 000 56
	AISI 316										
	stainless steel										